



Preliminary and Provisional

2-CHANNEL STEP-UP PWM CONTROLLERS

Features

- Complete PWM Power Control Circuitry
- Under-voltage Lockout Protection
- Totem pole Output
- Output Short Circuit Protection
- Dead Time Control : 0 to 100%
- Wide Operating Frequency :
10kHz to 800kHz
- Shut Down Control
- Power Good Protection

Pin Configuration

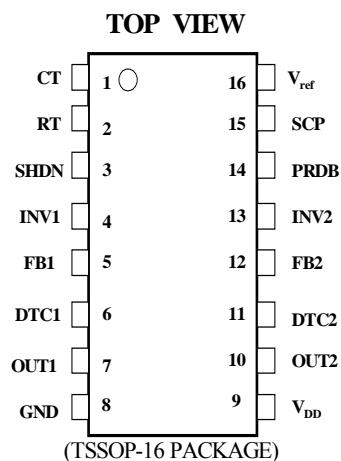

General Description

The AAT1106 series provides an integrated two-channel pulse-width-modulation (PWM) solution for the power supply of DC-DC system, this device offers the systems engineer the flexibility to tailor the power supply circuitry to a specific application. Each channel contains its own error amplifier, PWM comparator, dead-time control and output driver. The under-voltage protection, oscillator, short circuit protection and voltage reference circuit are common for the two channels.

The AAT1106 contains two boost (step-up) exclusive circuit. Dead-time control (DTC) can be set to provide 0% to 100% dead time by resistive divider network. Soft start can be implemented by paralleling the DTC resistor with a capacitor. Two dead time control inputs are assigned for Ch-1 and Ch-2 individually, and dead time control inputs can be used to control on / off operation.

With a minimum number of external components, the AAT1106 series offers a simple and cost effective solution.

*Spec is subject to change without notice in this document.

**Pin Description**

Pin #	Name	I/O	Description
1	CT	I	External timing capacitance
2	RT	I	External timing resistance
3	SHDN	I	Shut down input pin (internal pull "H")
4	INV1	I	Negative input for error amplifier 1
5	FB1	I	Output for error amplifier 1
6	DTC1	I	Output 1 dead time / soft start setting
7	OUT1	O	Output 1
8	GND		Ground
9	V _{DD}	I	Power supply
10	OUT2	O	Output 2
11	DTC2	I	Output 2 dead time / soft start setting
12	FB2	I	Output for error amplifier 2
13	INV2	I	Negative input for error amplifier 2
14	PRDB	I	Power good output pin
15	SCP	I	Timer latch setting
16	V _{ref}	O	Reference voltage (2.505V) output

**Absolute Maximum Ratings**

CHARACTERISTICS	SYMBOL	VALUE	UNIT
Supply voltage	V_{DD}	7	V
Input voltage (IN-, DTC, SHDN)	V_I	V_{DD}	V
Output voltage	V_O	$V_{DD}+0.3$	V
Output current	I_O	-120/+120	mA
Operating free-air temperature range	T_{ope}	-20 to 85	°C
Storage temperature range	T_{stg}	-65 to 150	°C
Power dissipation	P_d	500	mW

Recommended Operating Conditions

	Symbol	Min	Max	Unit
Supply voltage, V_{DD}	V_{DD}	4.0	6.5	V
Input voltage, INV1, INV2	V_{cm}	0.5	1.6	V
Output voltage	V_O	0	V_{DD}	V
OSC capacitor	C_T	100	15000	pF
OSC resistor (Note 1)	R_T	5.1	50	k Ω
Oscillator frequency	f_{OSC}	10	800	kHz
Output current, Iout1, Iout2	I_O		+50/-50	mA
Operating free-air temperature	T_{ope}	-20	85	°C

**Electrical Characteristics, $V_{DD} = 5.0V$ (Unless Otherwise Specified) (See Note 1)****Oscillator**

Parameter		Test Condition	Min	Typ	Max	Unit
Frequency	f_{OSC}	$C_T = 220pF, R_T = 10k\Omega$	320	400	480	KHz
Frequency change with V_{DD}	f_{dv}	$V_{DD} = 4.0V$ to $6.0V$, $T_A = 25^\circ C$ $C_T = 220pF, R_T = 10k\Omega$		1		%

Under-voltage Protection

Parameter		Test Condition	Min	Typ	Max	Unit
Upper threshold voltage	V_{UPH}	$T_A = 25^\circ C$	2.6	2.9	3.2	V
Lower threshold voltage	V_{UPL}	$T_A = 25^\circ C$	2.23	2.53	2.83	V
Hysteresis ($V_{UPH} - V_{UPL}$)	V_{HYS}	$T_A = 25^\circ C$		0.37		V

Short Circuit Protection Control

Parameter		Test Condition	Min	Typ	Max	Unit
Input threshold voltage	V_{r1}	Ch-1, 2	2.1	2.4	2.65	V
Short-circuit detect threshold voltage	V_{r2}		1.48	1.64	1.8	V
SCP terminal source current	I_{SCP}		-1.5	-2.5	-3.5	μA
Standby Voltage	V_{STB}			50	100	mV
Latch Voltage	V_{LT}			30	100	mV

Shun Down Control (Internal pull "H")

Parameter		Test Condition	Min	Typ	Max	Unit
Shut down enable voltage	V_{sdL}	$T_A = 25^\circ C$			0.5	V
Shut down release voltage	V_{sdH}	$T_A = 25^\circ C$	2.0			V

Note1 : Typical values of all parameters are specified at $T_A = 25^\circ C$.



Electrical Characteristics, $V_{DD} = 5.0V$ (Unless Otherwise Specified) (See Note 1) (continued)
Reference Voltage

Parameter		Test Conditions	Min	Typ	Max	Unit
Internal reference Voltage	V_{refi}	$I_{REF} = -1mA, T_A = 25^\circ C$	1.220	1.233	1.246	V
Reference voltage	V_{REF}	$I_{REF} = -1mA, T_A = 25^\circ C$	2.430	2.505	2.580	
Input voltage regulation	V_{RI}	$I_{REF} = -1mA,$ $V_{DD} = 4.0V \text{ to } 6.0V$		1	5	mV
Output regulation	V_{RO}	$I_{REF} = -0.1mA \text{ to } -1mA$		1		mV

EA (Error Amplifier)

Parameter		Test Condition	Min	Typ	Max	Unit
Input offset voltage	V_{IO}	Ch-1,2, $A_v=1$			6	mV
Input bias current	I_{IB}	Ch-1,2		± 15	± 100	nA
Input voltage range	V_{IR}	Ch-1,2	0.5		1.6	V
Open-loop voltage amplification	A_{VD}		70	85		dB
Output voltage swing	V_{OM+}		2.3	2.5		V
	V_{OM-}			0.7	0.9	
Output sink current	I_{OM+}	FB=1.25V	3	20		mA
Output source current	I_{OM-}	FB=1.25V	-45	-75		μA
Common-mode rejection ratio	CMRR		60	80		dB

**Electrical Characteristics, $V_{DD} = 5.0V$ (Unless Otherwise Specified) (See Note 1) (continued)****Dead Time Control & PWM**

Parameter		Test Condition	Min	Typ	Max	Unit
Input bias current	I_{BDT}	$V_{DTC} = 2V$		0.1	1	μA
Input threshold voltage (DTC)	V_{d0}	Duty = 0%, $f_{OSC} = 10kHz$	1.38	1.48	1.58	V
	V_{d100}	Duty = 100%, $f_{OSC} = 10kHz$	1.87	1.97	2.07	
Latch input voltage	V_{DT}	$I_{DT} = 100\mu A$		0.1	0.3	V
Latch mode source current	I_{DT}	DTC1,2=2.0V	200	500		μA

Output Stage

Parameter		Test Condition	Min	Typ	Max	Unit
High-level output voltage	V_{OH}	$I_O = -50mA$	3.6	4.0		V
Low-level output voltage	V_{OL}	$I_O = +50mA$		0.8	1.2	V
Rise time	T_{rise}	$C_L = 1000pF$		100		nS
Fail time	T_{fail}	$C_L = 1000pF$		100		nS
Leakage current	I_{peak}	$V_o = 6.0V$			5	μA

Operating Current

Parameter		Test Condition	Min	Typ	Max	Unit
Supply current	I_{DD-OFF}	Output "OFF" state		1.8		mA
	I_{DD-ON}	$P_{RT} = 10k$		2.0		mA



Function Block Diagram

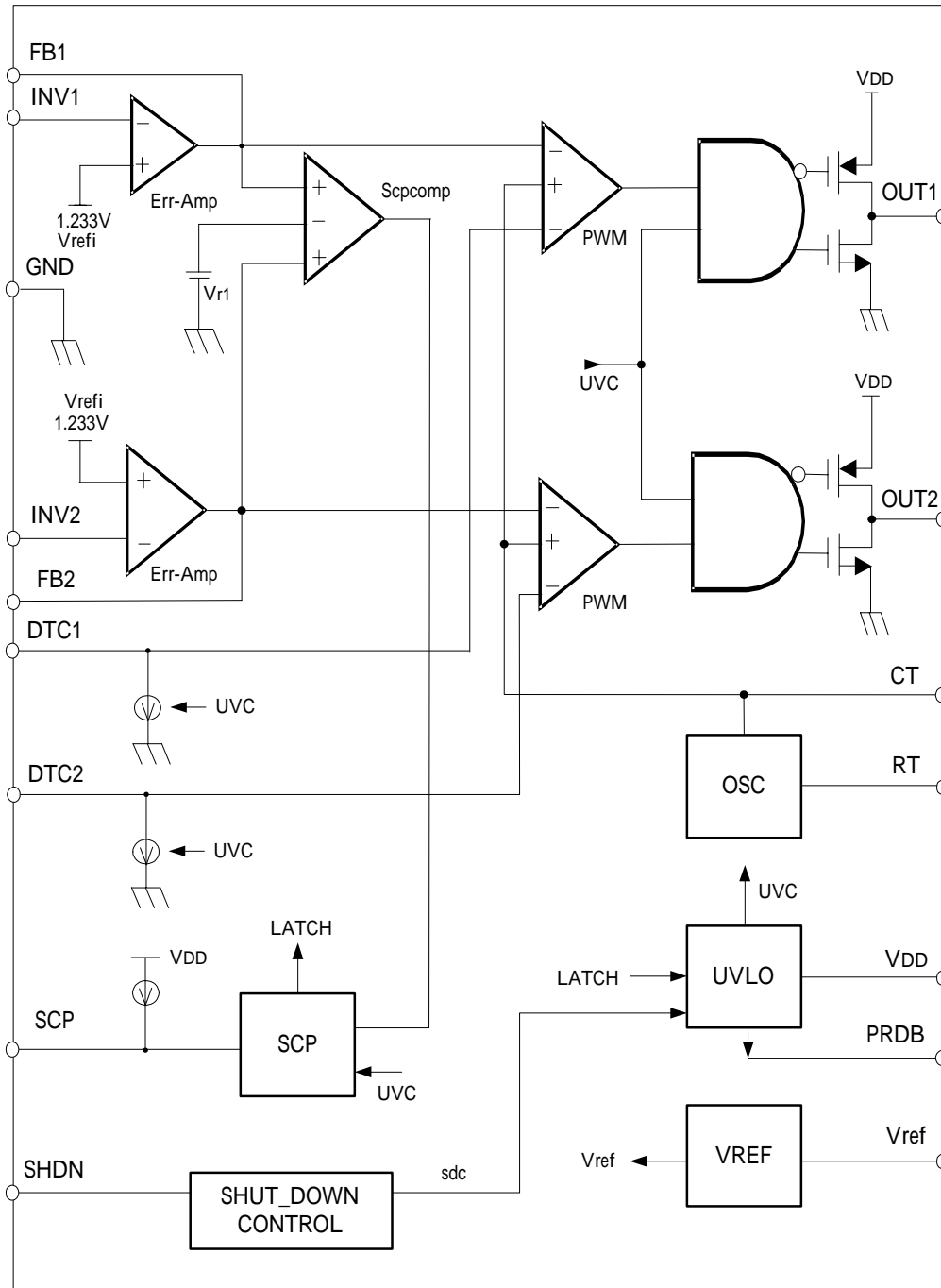



Application Circuit 1

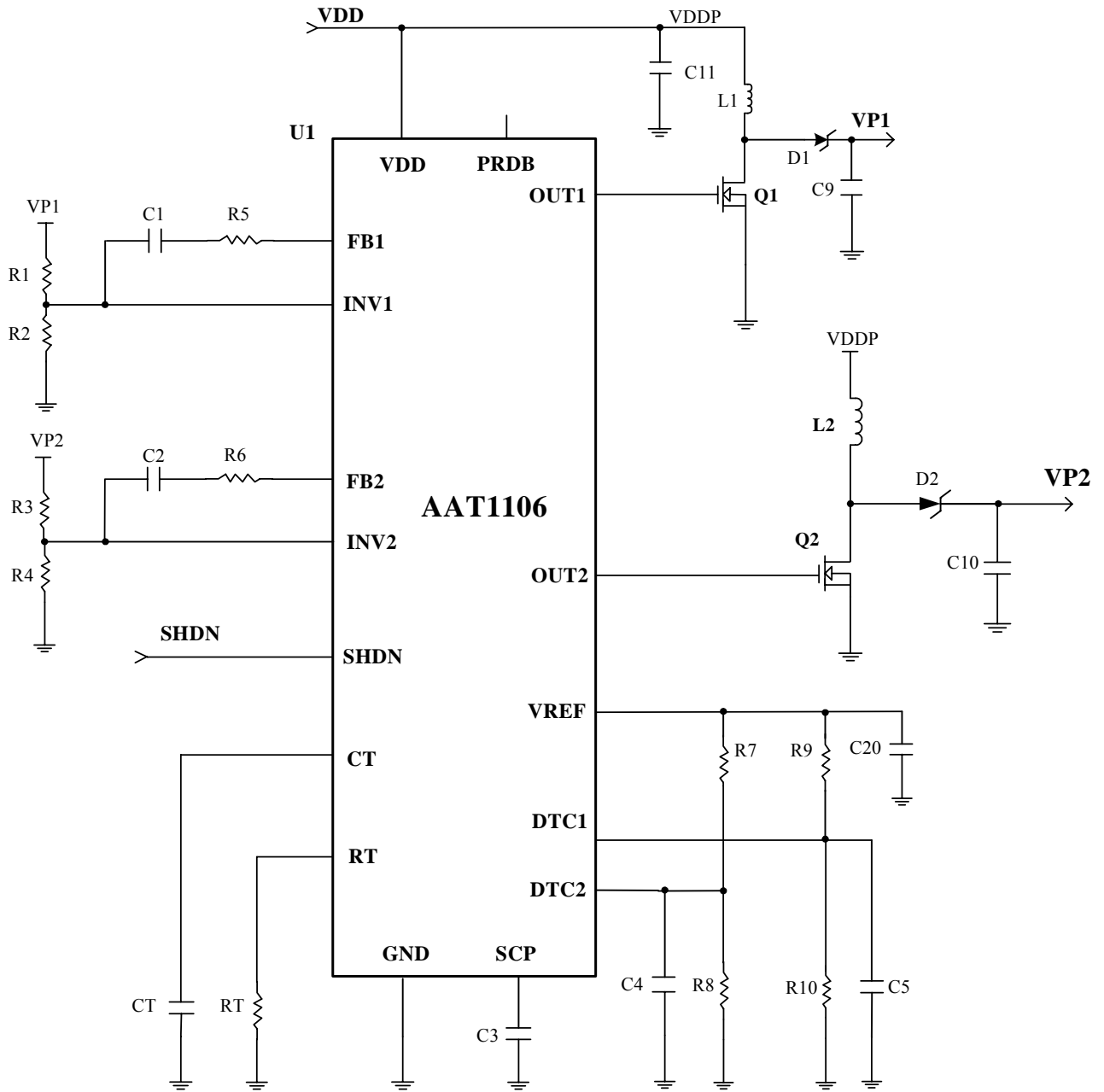



Application Circuit 2

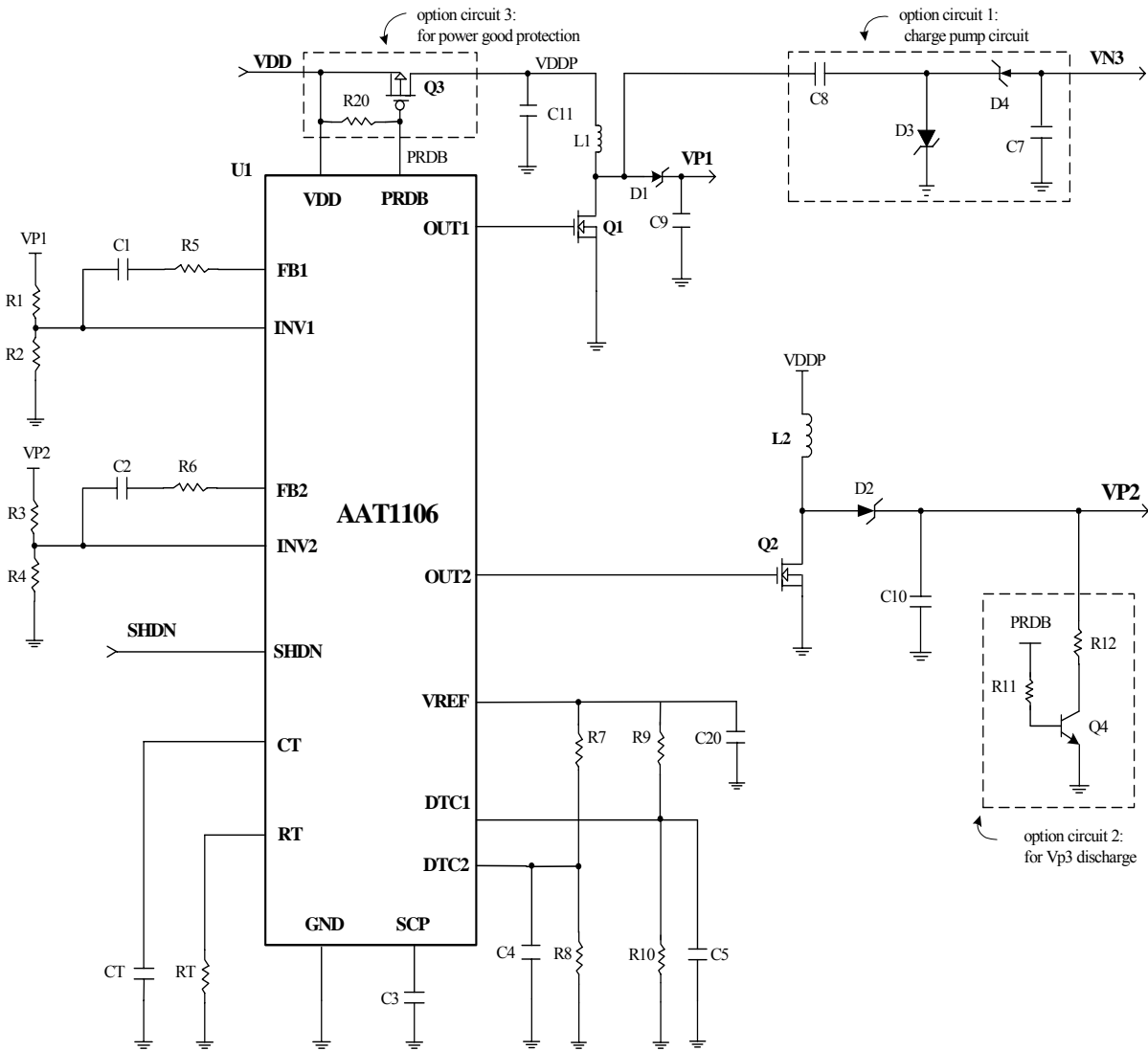



Boost (Step-up) Timing Chart

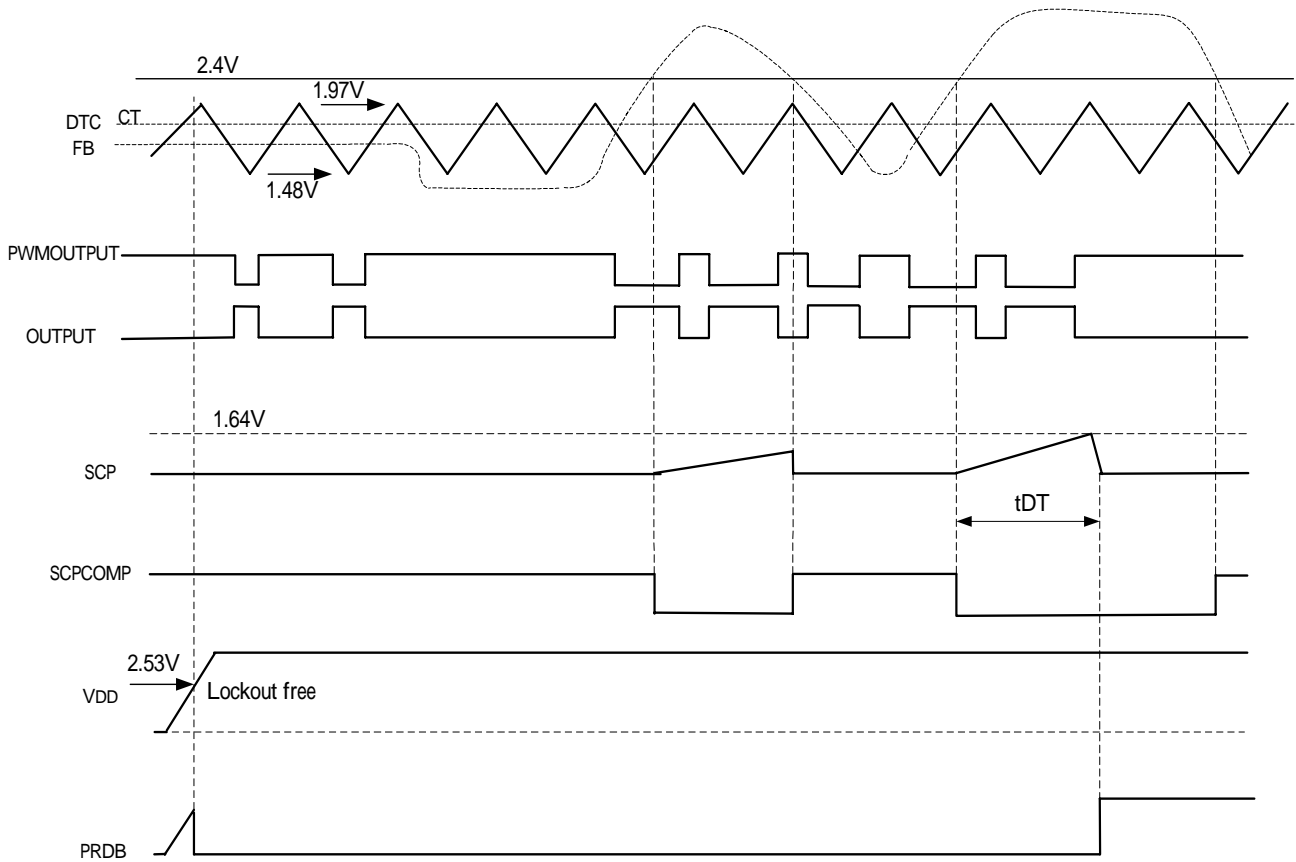



Package Dimension (Unit: Mil)

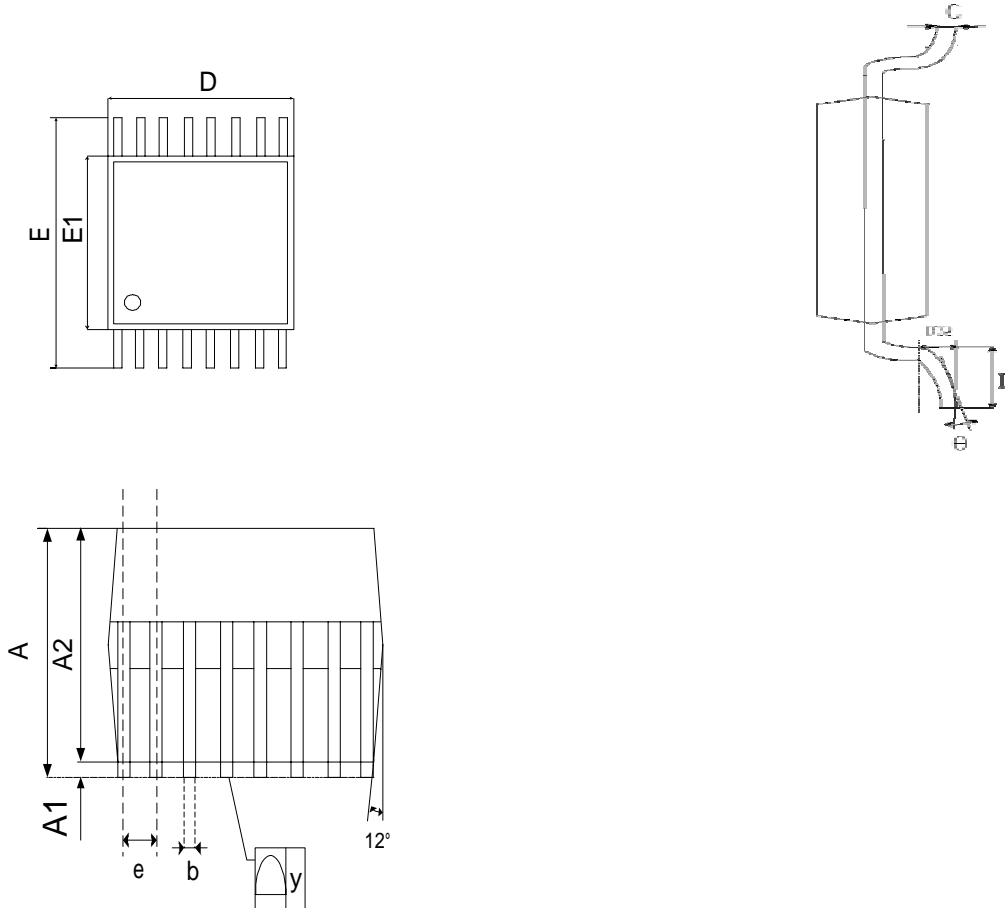

	DIMENSIONS IN MILLIMETERS			DIMENSIONS IN INCHES		
	MIN	NOM	MAX	MIN	NOM	MAX
A	1.05	1.10	1.20	0.041	0.043	0.047
A1	0.05	0.10	0.15	0.002	0.004	0.006
A2	—	1.00	1.05	—	0.039	0.041
b	0.20	0.25	0.28	0.008	0.010	0.011
C	—	0.127	—	—	0.005	—
D	4.90	5.075	5.10	0.193	0.1998	0.200
E	6.20	6.40	6.60	0.244	0.252	0.260
E1	4.30	4.40	4.50	0.170	0.173	0.177
e	—	0.65	—	—	0.026	—
L	0.5	0.60	0.70	0.02	0.024	0.028
y	—	—	0.076	—	—	0.003
	0°	4°	8°	0°	4°	8°